



Computer Networks

CS3953

Link Layer-Part 1

Haiming Jin

The slides are adapted from those provided by Prof. J.F Kurose and K.W. Ross.

Chapter 6: Link layer and LANs

our goals:

- understand principles behind link layer services:
 - error detection, correction
 - sharing a broadcast channel: multiple access
 - link layer addressing
 - local area networks: Ethernet, VLANs
- instantiation, implementation of various link layer technologies

Link layer, LANs: outline

6.1 introduction, services

6.2 error detection,
correction

6.3 multiple access
protocols

6.4 LANs

- addressing, ARP
- Ethernet
- switches
- VLANs

6.5 link virtualization:
MPLS

6.6 data center
networking

6.7 a day in the life of a
web request

Link layer: introduction

terminology:

- any device that runs a link-layer protocol (hosts, routers, switches, wifi access points) : **nodes**
- communication channels that connect adjacent nodes along communication path: **links**
 - wired links
 - wireless links
 - LANs
- link layer (layer-2) packet: **frame**, encapsulates datagram

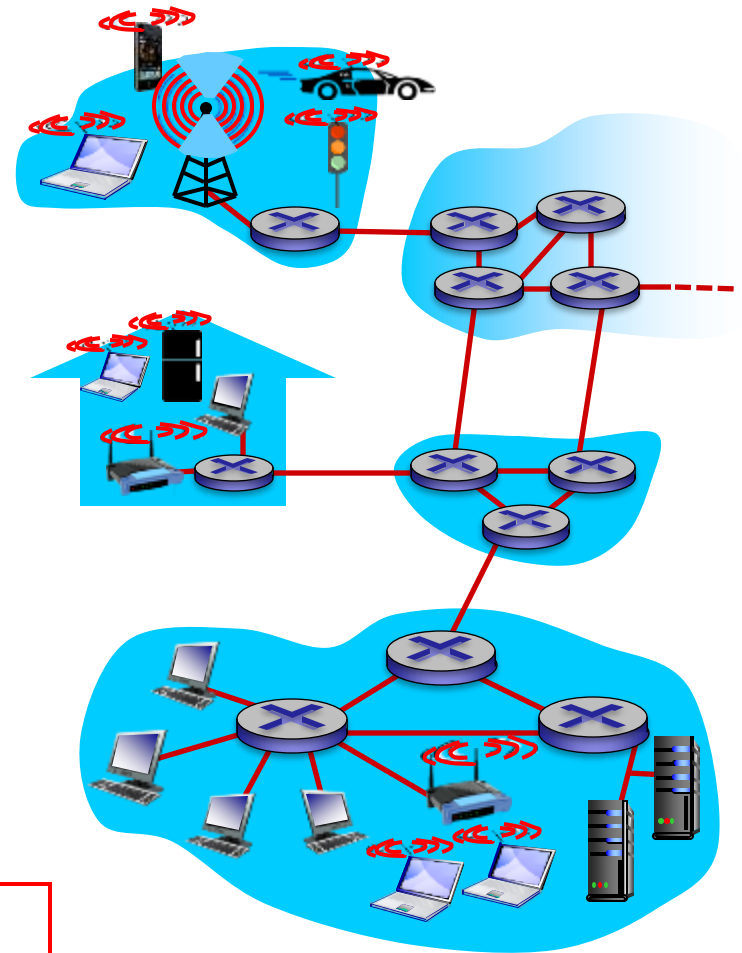

data-link layer has responsibility of transferring datagram from one node to *physically adjacent* node over a link

Link layer: context

- datagram transferred by different link protocols over different links:
 - e.g., Ethernet on first link, frame relay on intermediate links, 802.11 on last link
- each link protocol provides different services
 - e.g., may or may not provide rdt over link

Link layer services

- *framing, link access:*
 - encapsulate datagram into frame, adding header, trailer
 - channel access if shared medium
 - “MAC” addresses used in frame headers to identify source, destination
 - different from IP address!
- *reliable delivery between adjacent nodes*
 - we learned how to do this already (chapter 3)!
 - seldom used on low bit-error link (fiber, some twisted pair)
 - wireless links: high error rates
 - **Q:** why both link-level and end-end reliability?

Link layer services (more)

- *error detection:*
 - errors caused by signal attenuation, noise.
 - receiver detects presence of errors:
 - signals sender for retransmission or drops frame
- *error correction:*
 - receiver identifies *and corrects* bit error(s) without resorting to retransmission

Where is the link layer implemented?

- in each and every host
- link layer implemented in “adaptor” (aka *network interface card* NIC) or on a chip
 - Ethernet card, 802.11 card; Ethernet chipset
 - implements link, physical layer
- attaches into host’s system buses
- combination of hardware, software

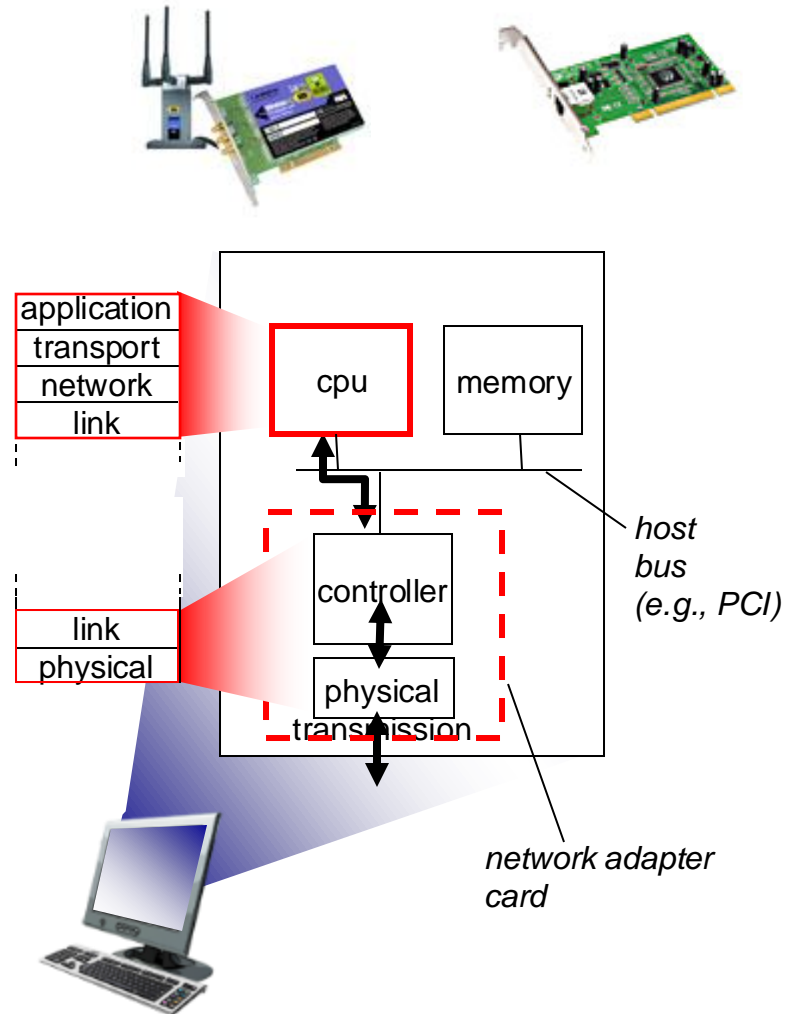

Adaptors communicating

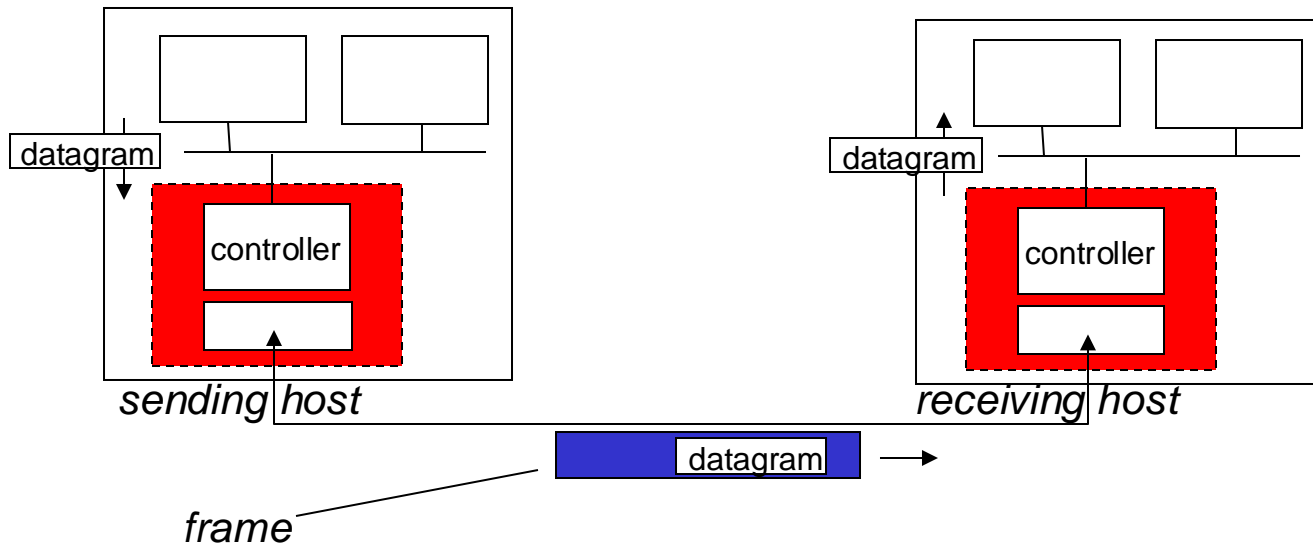

- sending side:
 - encapsulates datagram in frame
 - adds error checking bits, rdt, etc.
- receiving side
 - looks for errors, rdt, etc.
 - extracts datagram, passes to upper layer at receiving side

Link layer, LANs: outline

6.1 introduction, services

6.2 error detection,
correction

6.3 multiple access
protocols

6.4 LANs

- addressing, ARP
- Ethernet
- switches
- VLANs

6.5 link virtualization:
MPLS

6.6 data center
networking

6.7 a day in the life of a
web request

Error detection

EDC= Error Detection and Correction bits (redundancy)

D = Data protected by error checking, may include header fields

- Error detection not 100% reliable!
 - protocol may miss some errors, but rarely
 - larger EDC field yields better detection and correction

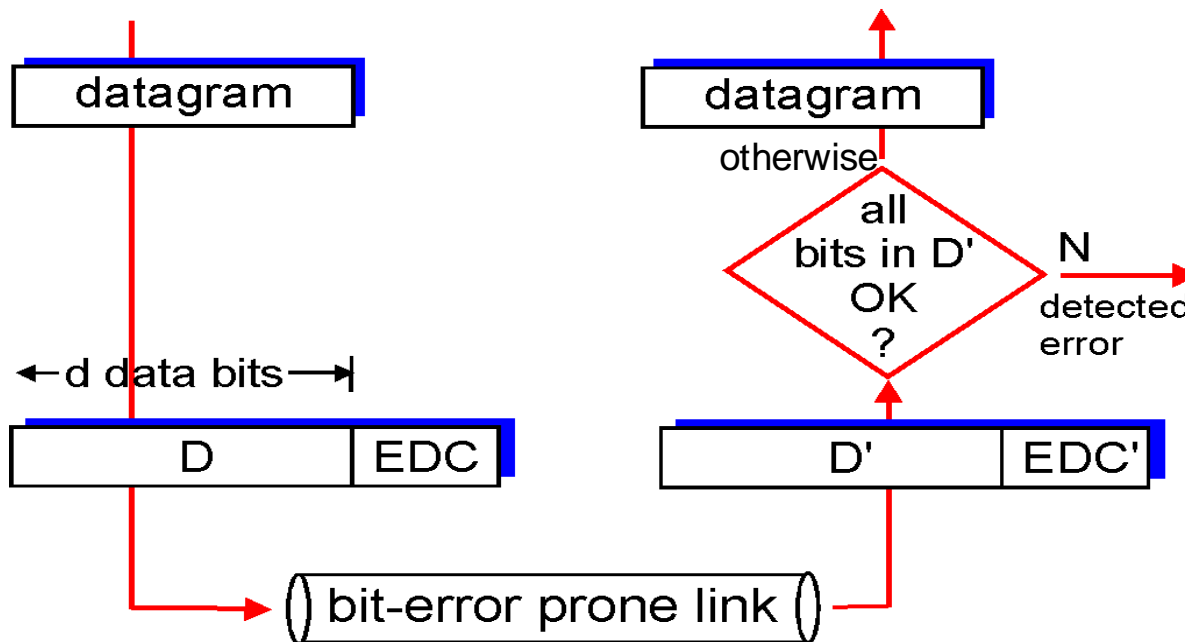

Parity checking

single bit parity:

- detect single bit errors

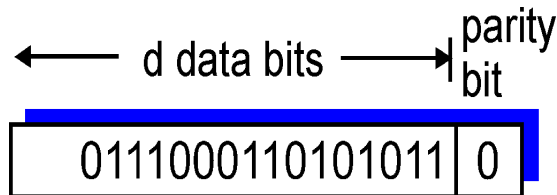

two-dimensional bit parity:

- detect and correct single bit errors

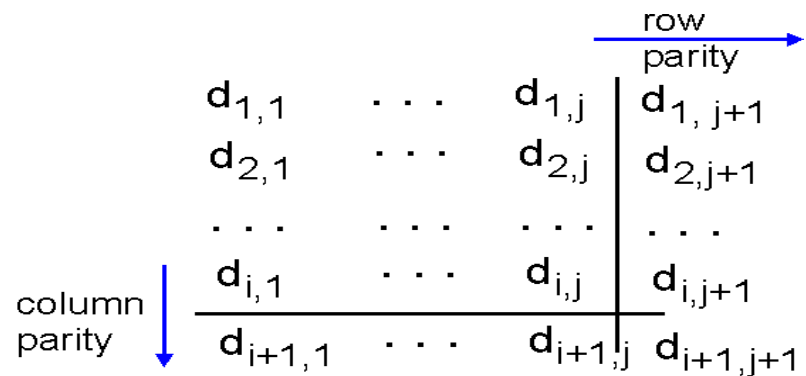

101011
111100
011101
001010

no errors

101011
1 1100
011101
001010

parity error

*correctable
single bit error*

* Check out the online interactive exercises for more examples: http://gaia.cs.umass.edu/kurose_ross/interactive/

Internet checksum (review)

goal: detect “errors” (e.g., flipped bits) in transmitted packet
(note: used at transport layer only)

sender:

- treat segment contents as sequence of 16-bit integers
- checksum: addition (1’s complement sum) of segment contents
- sender puts checksum value into UDP checksum field

receiver:

- compute checksum of received segment
- check if computed checksum equals checksum field value:
 - NO - error detected
 - YES - no error detected.
But maybe errors nonetheless?

Cyclic redundancy check

- more powerful error-detection coding
- view data bits, **D**, as a binary number
- choose $r+1$ bit pattern (generator), **G**
- goal: choose r CRC bits, **R**, such that
 - $\langle D, R \rangle$ exactly divisible by G (modulo 2)
 - receiver knows G , divides $\langle D, R \rangle$ by G . If non-zero remainder: error detected!
 - can detect all burst errors less than $r+1$ bits
- widely used in practice (Ethernet, 802.11 WiFi)

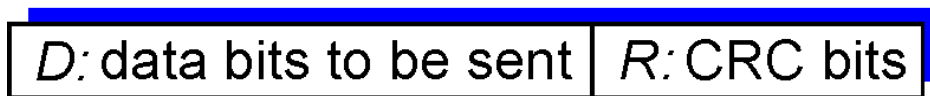
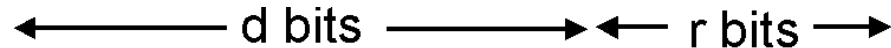

*bit
pattern*

$$D * 2^r \text{ XOR } R$$

*mathematical
formula*

CRC example

加不进位、减不借位，所以加和减等价于bit level的异或

want:

$$D \cdot 2^r \text{ XOR } R = nG$$

equivalently:

$$D \cdot 2^r = nG \text{ XOR } R$$

equivalently:

if we divide $D \cdot 2^r$ by G , want remainder R to satisfy:

$$R = \text{remainder}\left[\frac{D \cdot 2^r}{G}\right]$$

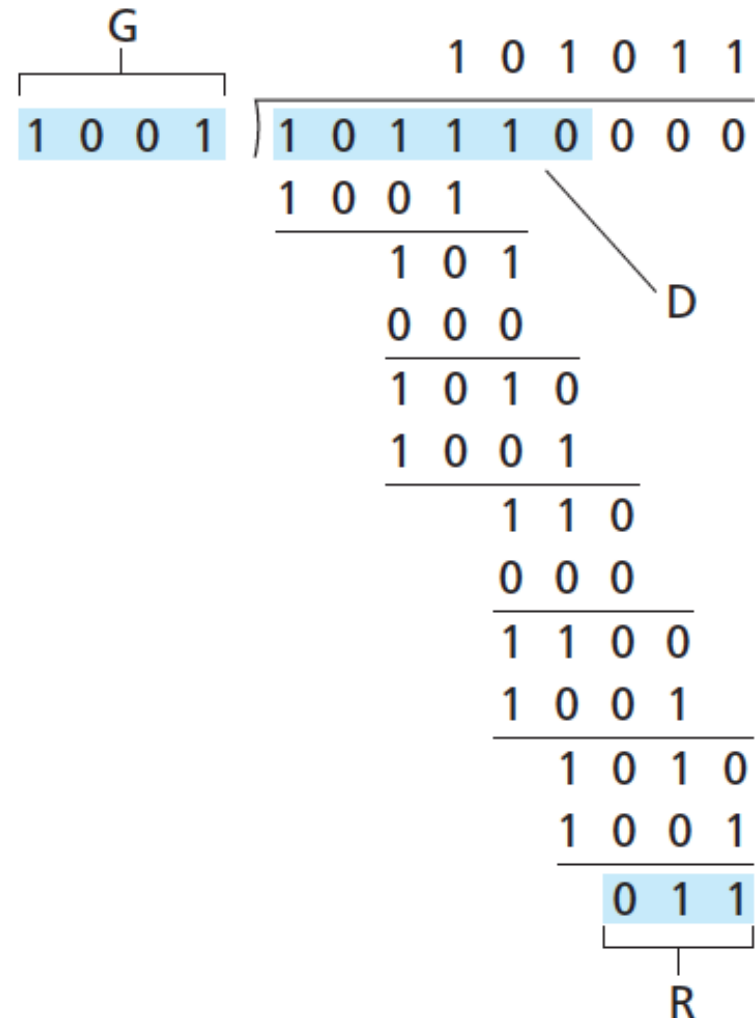

* Check out the online interactive exercises for more examples: http://gaia.cs.umass.edu/kurose_ross/interactive/

Link layer, LANs: outline

6.1 introduction, services

6.2 error detection,
correction

6.3 multiple access
protocols

6.4 LANs

- addressing, ARP
- Ethernet
- switches
- VLANs

6.5 link virtualization:
MPLS

6.6 data center
networking

6.7 a day in the life of a
web request

Multiple access links, protocols

two types of “links”:

- point-to-point
 - PPP for dial-up access
- *broadcast (shared wire or medium)*
 - Ethernet
 - 802.11 wireless LAN



shared wire (e.g.,
cabled Ethernet)



shared RF
(e.g., 802.11 WiFi)

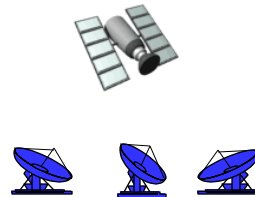

shared RF
(satellite)



humans at a
cocktail party
(shared air, acoustical)

Multiple access links, protocols



Multiple access protocols

- single shared broadcast channel
- two or more simultaneous transmissions by nodes:
interference
 - *collision* if node receives two or more signals at the same time

multiple access protocol

- distributed algorithm that determines how nodes share channel, i.e., determine when node can transmit
- communication about channel sharing must use channel itself!
 - no out-of-band channel for coordination

An ideal multiple access protocol

given: broadcast channel of rate R bps

desiderata:

1. when one node wants to transmit, it can send at rate R .
2. when M nodes want to transmit, each can send at average rate R/M
3. fully decentralized:
 - no special node to coordinate transmissions
 - no synchronization of clocks, slots
4. simple

MAC protocols: taxonomy

three broad classes:

- *channel partitioning*
 - divide channel into smaller “pieces” (time slots, frequency, code)
 - allocate piece to node for exclusive use
- *random access*
 - channel not divided, allow collisions
 - “recover” from collisions
- *“taking turns”*
 - nodes take turns, but nodes with more to send can take longer turns

Channel partitioning MAC protocols: TDMA

TDMA: time division multiple access

- access to channel in "rounds"
- each station gets fixed length slot (length = packet transmission time) in each round
- unused slots go idle
- example: 6-station LAN, 1,3,4 have packets to send, slots 2,5,6 idle

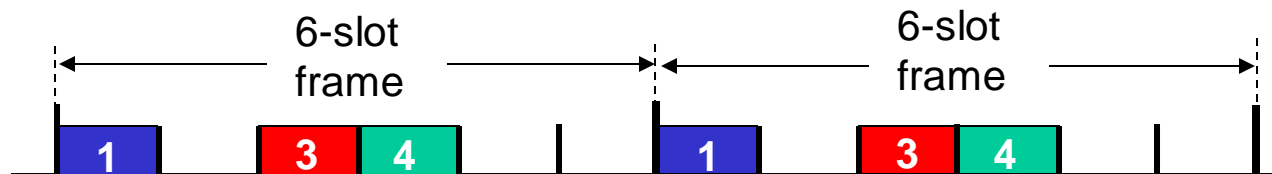

Channel partitioning MAC protocols: FDMA

FDMA: frequency division multiple access

- channel spectrum divided into frequency bands
- each station assigned fixed frequency band
- unused transmission time in frequency bands go idle
- example: 6-station LAN, 1,3,4 have packet to send, frequency bands 2,5,6 idle

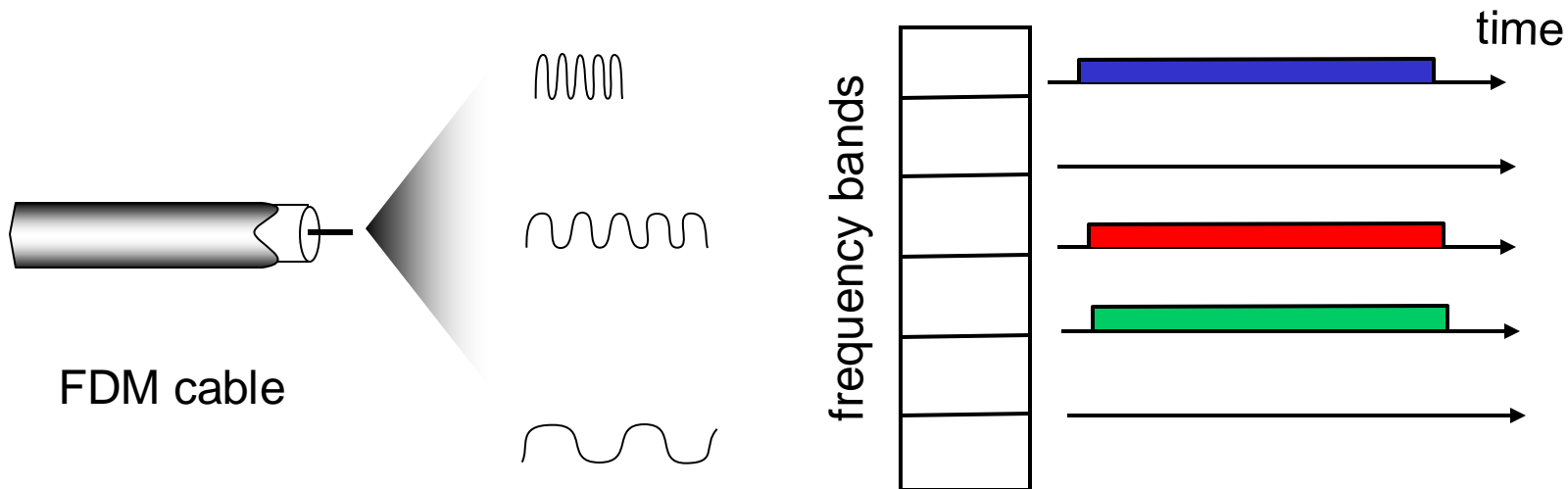

Random access protocols

- when node has packet to send
 - transmit at full channel data rate R .
 - no *a priori* coordination among nodes
- two or more transmitting nodes → “collision”,
- **random access MAC protocol** specifies:
 - how to detect collisions
 - how to recover from collisions (e.g., via delayed retransmissions)
- examples of random access MAC protocols:
 - slotted ALOHA
 - ALOHA
 - CSMA, CSMA/CD, CSMA/CA

Slotted ALOHA

assumptions:

- all frames same size
- time divided into equal size slots (time to transmit 1 frame)
- nodes start to transmit only at slot beginning
- nodes are synchronized
- if 2 or more nodes transmit in slot, all nodes detect collision

operation:

- when node has a fresh frame to send, transmits in next slot
 - *if no collision:* node can send new frame in next slot
 - *if collision:* node retransmits frame in each subsequent slot with prob. p until success

Slotted ALOHA

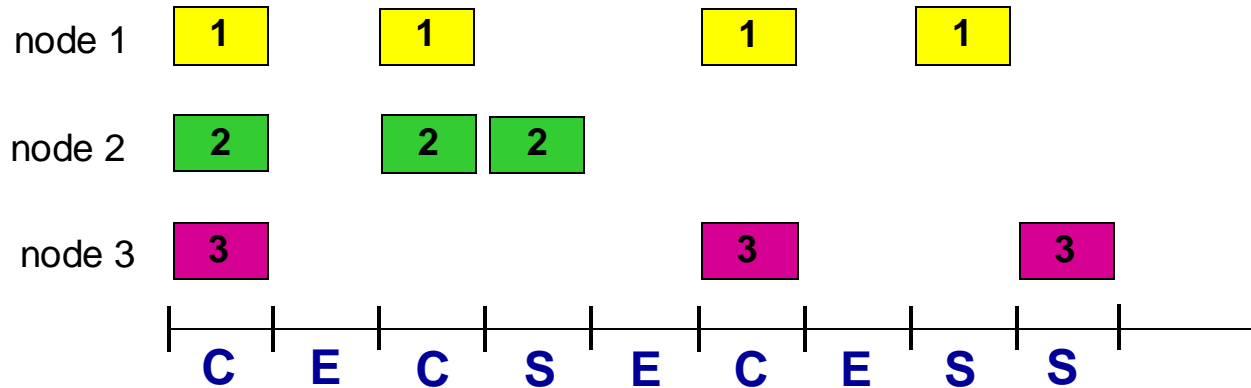

Pros:

- single active node can continuously transmit at full rate of channel
- highly decentralized: only slots in nodes need to be in sync
- simple

Cons:

- collisions, wasting slots
- idle slots
- nodes may be able to detect collision in less than time to transmit packet
- clock synchronization

Slotted ALOHA: efficiency

efficiency: long-run fraction of successful slots (many nodes, all with many frames to send)

- suppose: N nodes with many frames to send, each transmits in slot with probability p
- prob that given node has success in a slot = $p(1-p)^{N-1}$
- prob that *any* node has a success = $Np(1-p)^{N-1}$

- max efficiency: find p^* that maximizes $Np(1-p)^{N-1}$
- for many nodes, take limit of $Np^*(1-p^*)^{N-1}$ as N goes to infinity, gives:

$$\text{max efficiency} = 1/e = .37$$

at best: channel used for useful transmissions 37% of time!



Pure (unslotted) ALOHA

- unslotted Aloha: simpler, no synchronization
- when frame first arrives
 - transmit immediately
- collision probability increases:
 - frame sent at t_0 collides with other frames sent in $[t_0 - 1, t_0 + 1]$

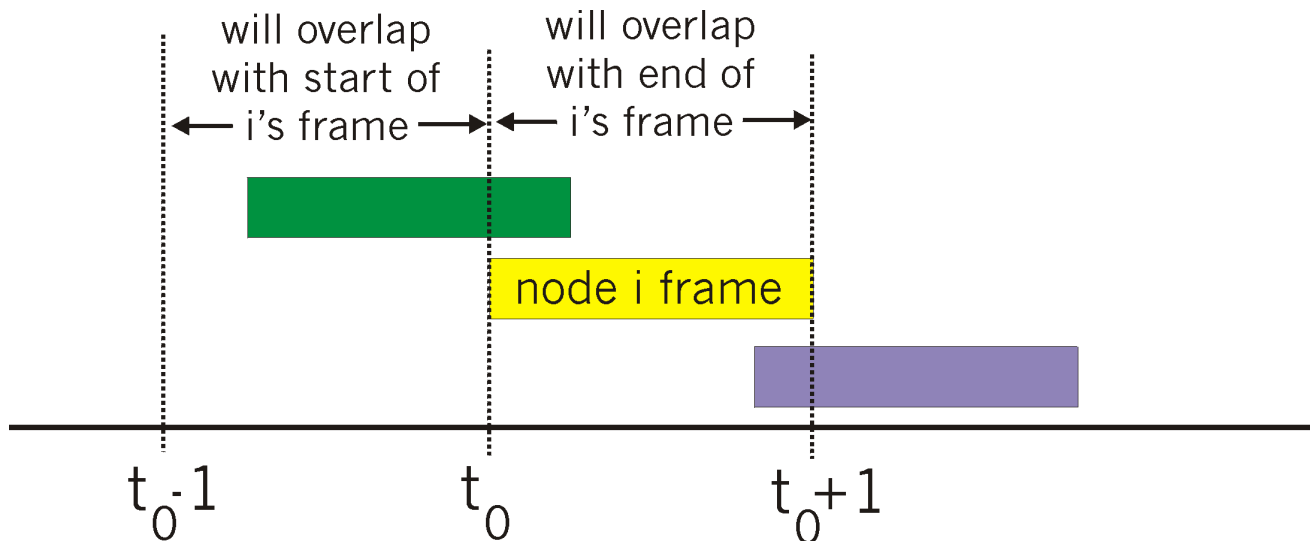

Pure ALOHA efficiency

$P(\text{success by given node}) = P(\text{node transmits}) \cdot$

$P(\text{no other node transmits in } [t_0-1, t_0]) \cdot$

$P(\text{no other node transmits in } [t_0, t_0+1])$

$$= p \cdot (1-p)^{N-1} \cdot (1-p)^{N-1}$$

$$= p \cdot (1-p)^{2(N-1)}$$

... choosing optimum p and then letting $n \rightarrow \infty$

$$= 1/(2e) = .18$$

even worse than slotted Aloha!

CSMA (carrier sense multiple access)

CSMA: listen before transmit:

if channel sensed idle: transmit entire frame

- if channel sensed busy, defer transmission

- human analogy: don't interrupt others!

CSMA collisions

- **collisions can still occur:** propagation delay means two nodes may not hear each other's transmission
- **collision:** entire packet transmission time wasted
 - distance & propagation delay play role in determining collision probability

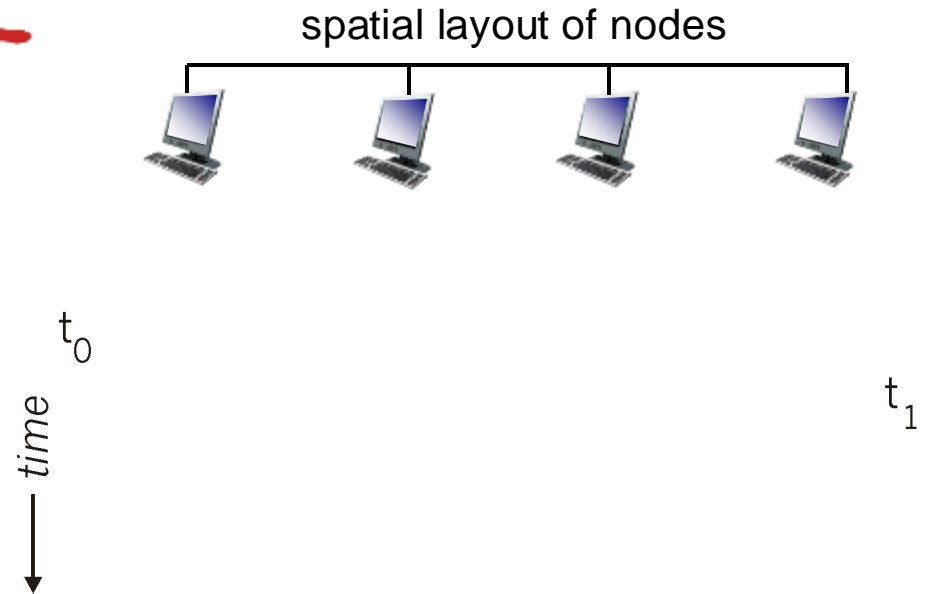

CSMA/CD (collision detection)

CSMA/CD: carrier sensing, deferral as in CSMA

- collisions *detected* within short time
- colliding transmissions aborted, reducing channel wastage
- collision detection:
 - easy in wired LANs: measure signal strengths, compare transmitted, received signals
 - difficult in wireless LANs: received signal strength overwhelmed by local transmission strength

CSMA/CD (collision detection)

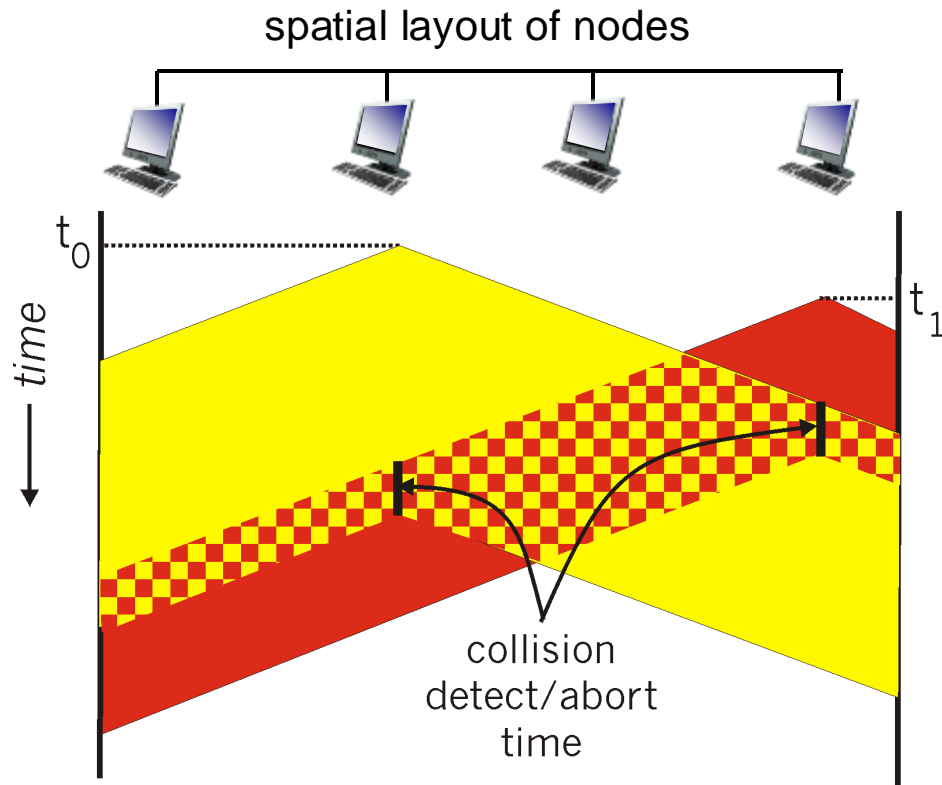

Ethernet CSMA/CD algorithm

1. NIC receives datagram from network layer, creates frame
2. If NIC senses channel idle, starts frame transmission. If NIC senses channel busy, waits until channel idle, then transmits.
3. If NIC transmits entire frame without detecting another transmission, NIC is done with frame !
4. If NIC detects another transmission while transmitting, aborts
5. After aborting, NIC enters *binary (exponential) backoff*: 二进制指数退避
 - after m th collision, NIC chooses K at random from $\{0, 1, 2, \dots, 2^m - 1\}$. NIC waits $K \cdot 512$ bit times, returns to Step 2
 - longer backoff interval with more collisions

CSMA/CD efficiency

efficiency: long-run fraction of time during which frames being transmitted on the channel without collisions
(many nodes, all with many frames to send)

- T_{prop} = max prop delay between 2 nodes in LAN
- t_{trans} = time to transmit max-size frame

$$efficiency = \frac{1}{1 + 5t_{prop}/t_{trans}}$$

- efficiency goes to 1
 - as t_{prop} goes to 0
 - as t_{trans} goes to infinity
- better performance than ALOHA: and simple, cheap, decentralized!

IEEE 802.11: multiple access

- avoid collisions: 2+ nodes transmitting at same time
- 802.11: CSMA - sense before transmitting
 - don't collide with ongoing transmission by other node
- 802.11: *no* collision detection!
 - difficult to receive (sense collisions) when transmitting due to weak received signals (fading)
 - can't sense all collisions in any case: hidden terminal, fading
 - goal: *avoid collisions*: CSMA/C(ollision)A(voidance)

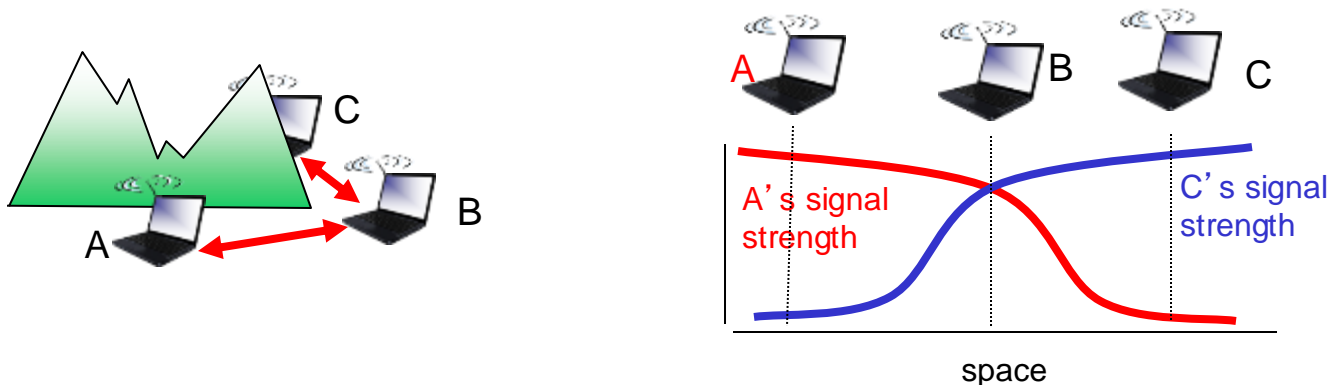

IEEE 802.11 MAC Protocol: CSMA/CA

802.11 sender

- 1 if sense channel idle for **DIFS** then
transmit entire frame (no CD)
- 2 if sense channel busy then
start random backoff time (binary exponential
backoff)
timer counts down **while channel idle**
transmit when timer expires
if no ACK, increase random backoff interval, repeat 2

802.11 receiver

- if frame received OK
return ACK after **SIFS** (ACK needed due to hidden
terminal problem)

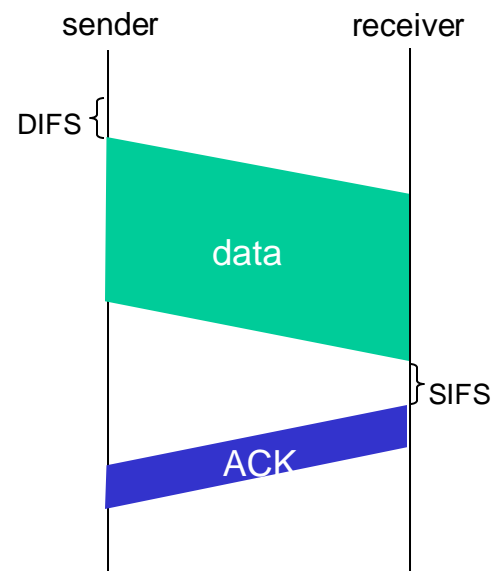

Avoiding collisions (more)

idea: sender “reserves” channel use for data frames using small reservation packets

- sender first transmits *small* request-to-send (RTS) packet to BS using CSMA
 - RTSs may still collide with each other (but they’re short)
- BS broadcasts clear-to-send CTS in response to RTS
- CTS heard by all nodes
 - sender transmits data frame
 - other stations defer transmissions

Collision Avoidance: RTS-CTS exchange

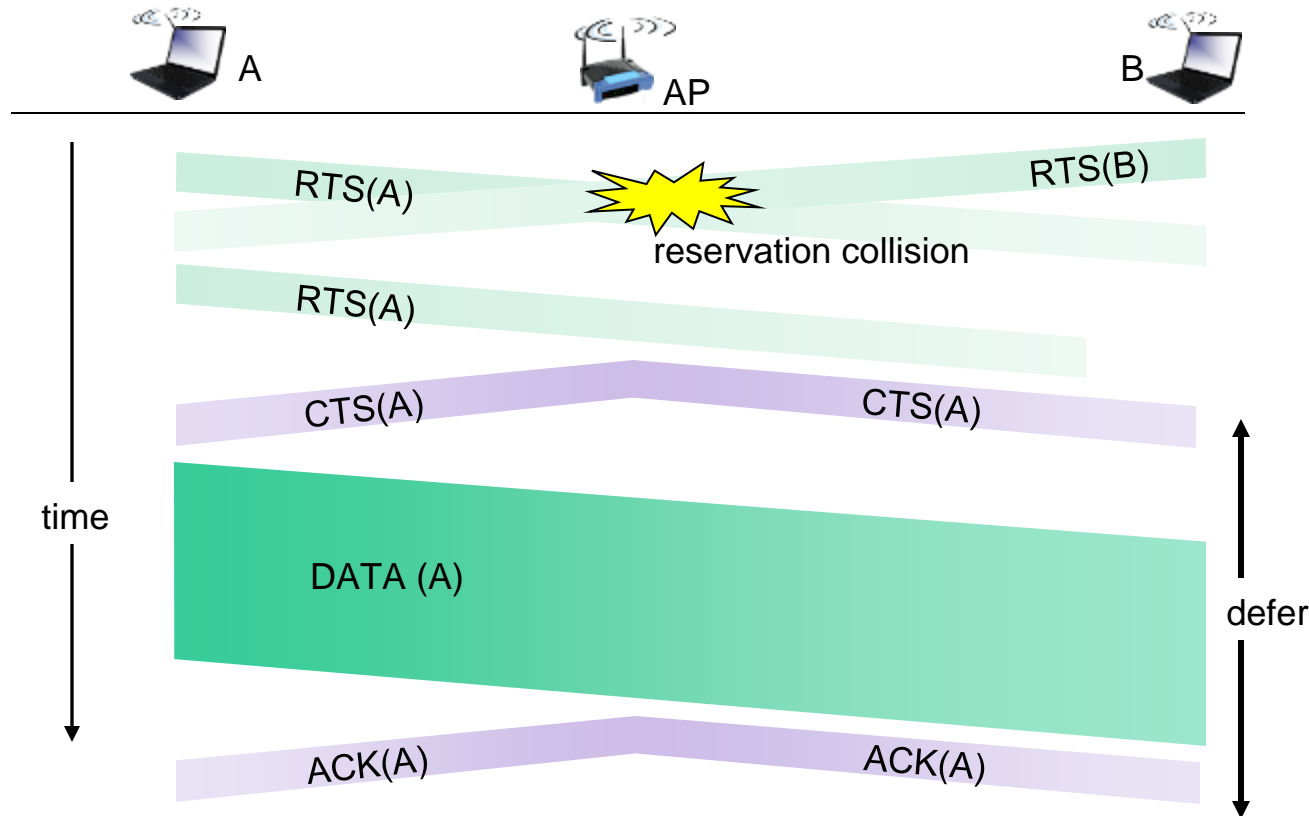

Summary

Protocol	Feature
Aloha	Talk whenever you want 想说就说
CSMA	Listen before speak 先听后说
CSMA/CD	Listen before speak, stop when colliding, backoff 先听后说, 碰撞停止, 退避机制
CSMA/CA	Listen before speak, ACK, Backoff 先听后说, ACK, 退避机制

“Taking turns” MAC protocols

channel partitioning MAC protocols:

- share channel *efficiently* and *fairly* at high load
- inefficient at low load: delay in channel access, $1/N$ bandwidth allocated even if only 1 active node!

random access MAC protocols

- efficient at low load: single node can fully utilize channel
- high load: collision overhead

“taking turns” protocols

look for best of both worlds!

“Taking turns” MAC protocols

polling:

- master node “invites” slave nodes to transmit in turn
- typically used with “dumb” slave devices
- concerns:
 - polling overhead
 - latency
 - single point of failure (master)

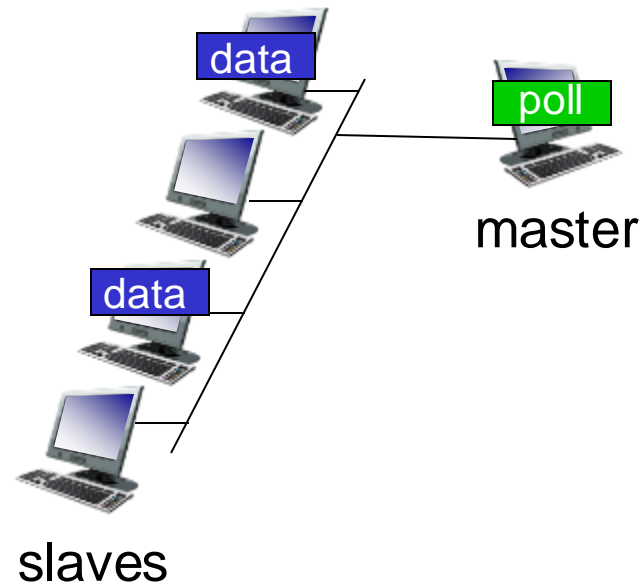

“Taking turns” MAC protocols

token passing:

- control *token* passed from one node to next sequentially.
- token message
- concerns:
 - token overhead
 - latency
 - single point of failure (token)

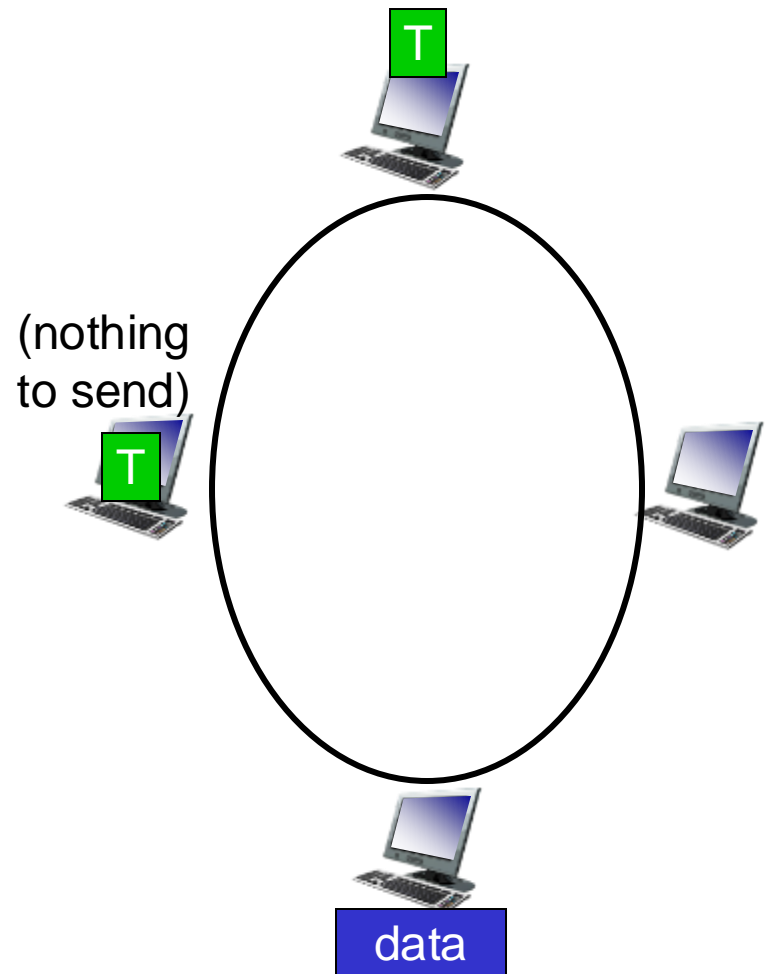

Summary of MAC protocols

- *channel partitioning*, by time, frequency or code
 - Time Division, Frequency Division
- *random access* (dynamic),
 - ALOHA, S-ALOHA, CSMA, CSMA/CD
 - carrier sensing: easy in some technologies (wire), hard in others (wireless)
 - CSMA/CD used in Ethernet
 - CSMA/CA used in 802.11
- *taking turns*
 - polling from central site, token passing
 - Bluetooth, FDDI, token ring